

Napkins are easily loaded into the self-feeding stacking bin

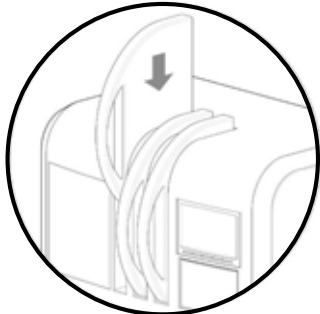

The silverware cartridges are easy to load, clean and install



Hidden behind the decorative louvered doors is lots of storage for full or empty bins, cartridges and supplies.

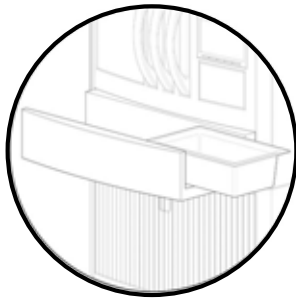
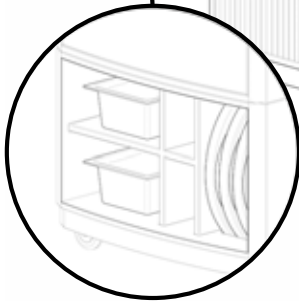

Once the Napwrap has completed the rolling cycle, the user uses the control panel to open the bin door. The full bin is easily removed or slid either right or left onto a rolling cart.

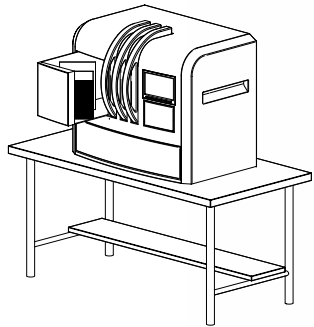

The Napwrap machine can sit on any table or optional rolling base.



The touchscreen user interface is intuitive, graphical and informative.



The tape roll access door allows easy changing of tape rolls.

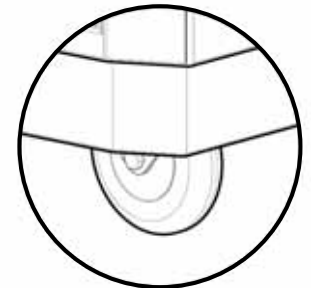

6" rubber casters allow quiet and easy rolling over any floor